



Link-Belt[®]

C R A N E S

RTC 8090^{II}

Rough Terrain Crane 90-ton | 80 mt

- 38-140 ft (11.6-42.7 m) five section, full power latching boom with quick reeve boom head
- Three boom extend modes
- 35-58 ft (10.7-17.7 m) two piece fly with offset of 2°, 15°, 30°, and 45°— optional
- Two 16 ft (4.9 m) lattice inserts plus 58 ft (17.7 m) two-piece offsettable fly — optional
- No deducts for stowed attachments
- 238 ft (72.5 m) maximum tip height
- 16,880 lbs (7 656.6 kg) maximum winch line pull
- 459 fpm (139.9 m/min) maximum winch line speed
- Spicer 6-speed power shift transmission
- 4x2 and 4x4 drive with 29.5x25-28PR tires
- Four steering modes: independent front, combination, crab, and independent rear
- 4 link rear suspension with optional hydro-gas suspension

RTC 8090

90-ton (80 mt) Rough Terrain Crane

Remarkable control, reliability and capacity performance

- **Powerful Cummins QSB 6.7 diesel engine** with 270hp (201kW) and direct coupled transmission
- Electronic throttle for improved throttle response
- **Two automotive-style batteries** linked in parallel provide 700 cold cranking amps each for cold weather starting
- **Hydraulic disc brakes** for both service brakes and parking brake
- **Metri-Pak wire harnesses** have sealed relays and connectors throughout for outstanding long-term reliability. All wires have flame retardant polyethylene insulation, resulting in a higher heat resistant wiring system.

Latching boom with attachment flexibility

- 38-140 ft (11.6-42.7 m) **five-section boom** with three extend modes.
- **No charted capacity reductions** for telescoping loads
- **Boom wear pads** have Teflon pucks that lubricate the boom sections (no grease)
- **Wireless windspeed indicator**
- **Maximum tip height** is 238 ft with the attachment and main boom used in combination
- Optional 35 ft (10.7 m) **one-piece lattice fly** and optional 35 ft to 58 ft (10.7 m to 17.7 m) **two-piece bi-fold lattice fly** are offsettable to 2°, 15°, 30° and 45°
- Optional two 16 ft (4.9 m) **lattice inserts** plus 58 ft (17.7 m) **two-piece offsettable fly**

Powerful hydraulics

- For greater productivity and control, the **five-pump hydraulic circuit** allows simultaneous function of boom hoist, winch and swing.
- Piston motor hydraulic hoist system delivers **superior hoisting**. Matched sizes of main and auxiliary winches provide equal maximum available line pulls of 16,880 lbs (7 656.6 kg) and maximum line speeds of 459 fpm (140 m/min) on 16" (40.6 cm) root diameter drums.

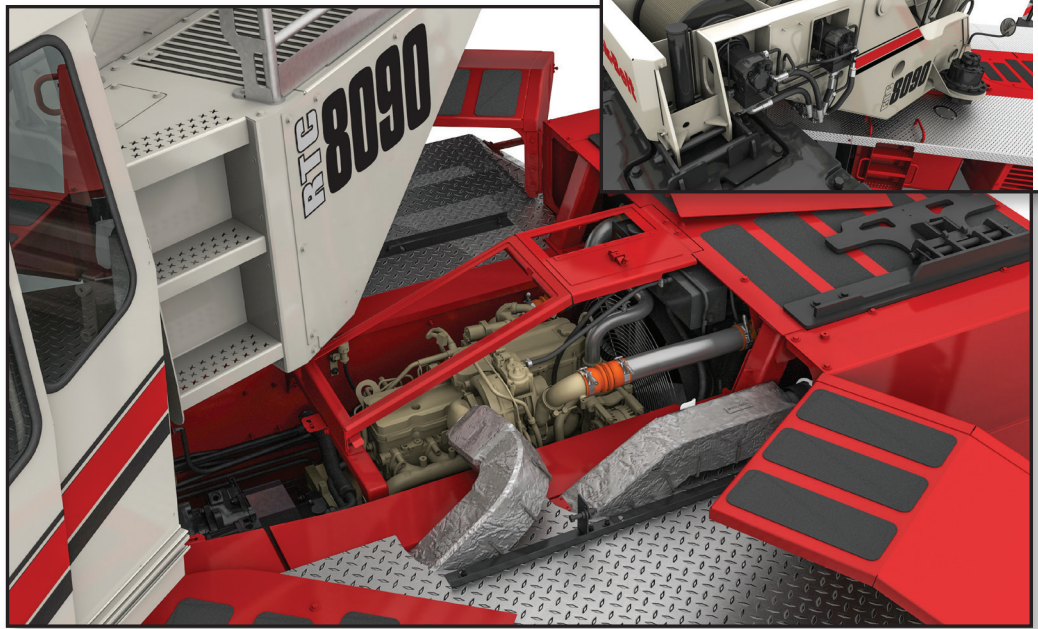

Operator's cab features

- **Extra large front window** almost seamlessly merges into the roof window
- **Excellent ventilation** via a large sliding door, side and rear windows, and hinged roof window
- All gauges, switches, indicators, and controls are located in the **operator's forward line of sight**
- **Single or dual axis**, pilot operated controller mounted on armrest of outstanding operator comfort
- Link-Belt vision package including **winch, right side swing, and rear-view cameras**
- Link-Belt **Pulse Operating System**
- **Integral rated capacity limiter** aids operator in safe and efficient operation by continuously monitoring boom length, boom angle, head height, radius of load, machine configuration, allowed load, and percent of allowed load.
- Cab mounted **warning lights**
- **Internal rated capacity limiter light bar**
- Available — **Integrated air conditioning** utilizes the same ventilation outlets as the standard heating system

Link-Belt
PULSE

Transport and jobsite maneuverability

- Base machine transport weight less than **90,000 lbs (40 823.3kg)**
- **Folding front and rear ladders** to prevent damage during loading and unloading for transport
- Rugged, lightweight **steel pontoons** with storage locations for transport
- **Steering modes** are chosen and performed with the steering wheel and include independent front, combination, "crab", and independent rear steering.
- **4-Link** suspension on the rear axle with an optional Hydro-Gas Ride™ system
- **Wide profile lug-type tires** for excellent traction in muddy and sanding conditions
- **CALC**—Outrigger beams extend to three different positions (retracted, intermediate, and fully extended) providing lifting capacities in confined areas.

Designed for easy access and service

- **Full-length flat deck** with integrated steps and handholds
- **Lockable engine compartment**
- **Large swing out engine hood doors** for ease of service
- Filters and serviceable items are **easy to access**.

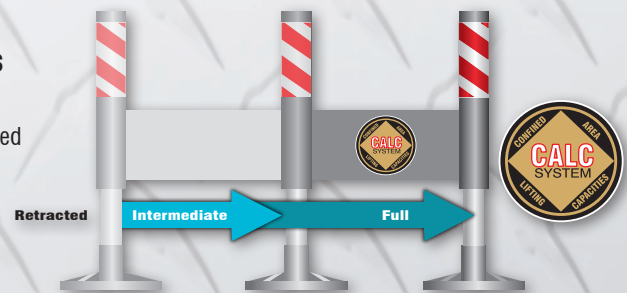

Link-Belt
CRANES
Lexington, Kentucky | www.linkbelt.com

© Link-Belt is a registered trademark. Copyright 2018. All rights reserved. We reserve the right to change designs and specifications at any time. Litho in U.S.A. 2/18 2063 #4526 (supersedes #4328)

Technical Data

Specifications & Capacities

RTC 8090

Series II
Telescopic Boom Rough Terrain Crane
90 US ton
80 metric ton

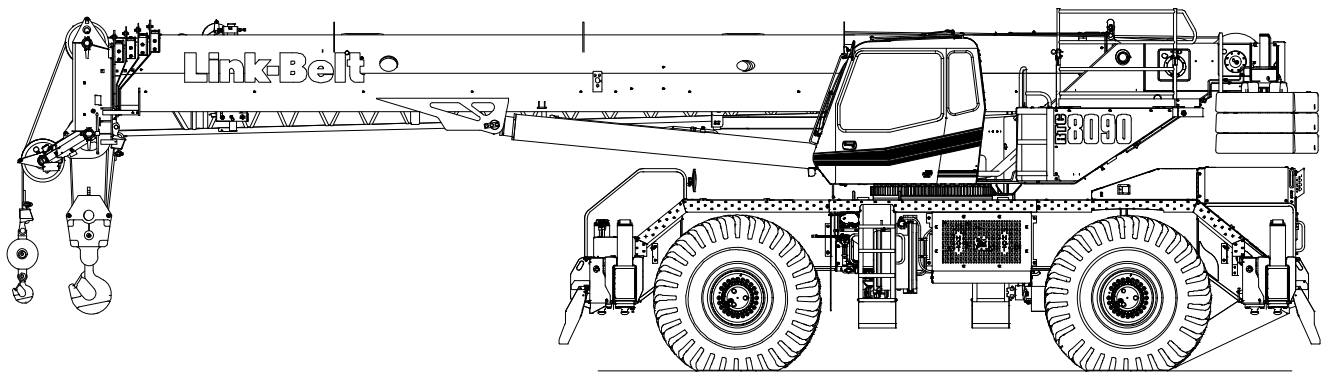

CAUTION: This material is supplied for reference use only. Operator must refer to in-cab Crane Rating Manual and Operator's Manual to determine allowable crane lifting capacities and assembly and operating procedures.

Table Of Contents

Boom, Attachments, and Upper Structure	1
Boom	1
Boom	1
Boom Wear Pads	1
Boom Head	1
Boom Elevation	1
Auxiliary Lifting Sheave – Optional	1
Hook Blocks and Balls – Optional	1
Fly – Optional	1
Fly Extensions – Optional	1
Operator’s Cab and Controls	2
Swing	3
Electrical	3
Load Hoist System	4
Load Hoist Performance	4
2M Main and Optional Auxiliary Winches	4
Hydraulic System	4
Counterweight	4
Carrier	5
General	5
Outriggers	5
Steering and Axles	5
Suspension	5
Tires and Wheels	5
Brakes	5
Electrical	5
Engine	5
Transmission	5
Fuel Tank	6
Hydraulic System	6
Maximum Speed	6
Gradeability	6
Pump Drive	6
Paint	6
Axle Loads	7
General Dimensions	8
General Dimensions	9
Working Range Diagram	10
Boom Extend Modes	11
Main Boom Lift Capacity Charts – Imperial	12
19,200 lb Counterweight – Fully Extended Outriggers – 360° Rotation	12
19,200 lb Counterweight – On Tires – Stationary – Boom Centered Over Front Between Tire Tracks	13
19,200 lb Counterweight – On Tires – Pick & Carry (Creep) – Boom Centered Over Front	14
19,200 lb Counterweight – On Tires – Stationary – 360° Rotation	14
28,800 lb Counterweight – Fully Extended Outriggers – 360° Rotation	15

Fly Attachment Lift Capacity Charts – Optional	16
19,200 lb Counterweight – Fully Extended Outriggers – 360° Rotation	16
140 ft Main Boom Length – 2° Fly Offset	16
140 ft Main Boom Length – 15° Fly Offset	16
19,200 lb Counterweight – Fully Extended Outriggers – 360° Rotation	17
140 ft Main Boom Length – 30° Fly Offset	17
140 ft Main Boom Length – 45° Fly Offset	17
28,800 lb Counterweight – Fully Extended Outriggers – 360° Rotation	18
140 ft Main Boom Length – 2° Fly Offset	18
140 ft Main Boom Length – 15° Fly Offset	18
28,800 lb Counterweight – Fully Extended Outriggers – 360° Rotation	19
140 ft Main Boom Length – 30° Fly Offset	19
140 ft Main Boom Length – 45° Fly Offset	19
Main Boom Lift Capacity Charts – 75% – Metric	20
8.8t Counterweight – Fully Extended Outriggers – 360° Rotation	20
8.8t Counterweight – On Tires – Stationary – Boom Centered Over Front Between Tire Tracks	21
8.8t Counterweight – On Tires – Pick & Carry (Creep) – Boom Centered Over Front	22
8.8t Counterweight – On Tires – Stationary – 360° Rotation	22
13.2t Counterweight – Fully Extended Outriggers – 360° Rotation	23
Fly Attachment Lift Capacity Charts – 75% – Optional	24
8.8t Counterweight – Fully Extended Outriggers – 360° Rotation	24
42.67m Main Boom Length – 2° Fly Offset	24
42.67m Main Boom Length – 15° Fly Offset	24
8.8t Counterweight – Fully Extended Outriggers – 360° Rotation	25
42.67m Main Boom Length – 30° Fly Offset	25
42.67m Main Boom Length – 45° Fly Offset	25
13.2t Counterweight – Fully Extended Outriggers – 360° Rotation	26
42.67m Main Boom Length – 2° Fly Offset	26
42.67m Main Boom Length – 15° Fly Offset	26
13.2t Counterweight – Fully Extended Outriggers – 360° Rotation	27
42.67m Main Boom Length – 30° Fly Offset	27
42.67m Main Boom Length – 45° Fly Offset	27
Main Boom Lift Capacity Charts – 85% – Metric	28
8.8t Counterweight – Fully Extended Outriggers – 360° Rotation	28
8.8t Counterweight – On Tires – Stationary – Boom Centered Over Front Between Tire Tracks	29
8.8t Counterweight – On Tires – Pick & Carry (Creep) – Boom Centered Over Front	30
8.8t Counterweight – On Tires – Stationary – 360° Rotation	30
13.2t Counterweight – Fully Extended Outriggers – 360° Rotation	31
Fly Attachment Lift Capacity Charts – 85% – Optional	32
8.8t Counterweight – Fully Extended Outriggers – 360° Rotation	32
42.67m Main Boom Length – 2° Fly Offset	32
42.67m Main Boom Length – 15° Fly Offset	32
8.8t Counterweight – Fully Extended Outriggers – 360° Rotation	33
42.67m Main Boom Length – 30° Fly Offset	33
42.67m Main Boom Length – 45° Fly Offset	33
13.2t Counterweight – Fully Extended Outriggers – 360° Rotation	34
42.67m Main Boom Length – 2° Fly Offset	34
42.67m Main Boom Length – 15° Fly Offset	34
13.2t Counterweight – Fully Extended Outriggers – 360° Rotation	35
42.67m Main Boom Length – 30° Fly Offset	35
42.67m Main Boom Length – 45° Fly Offset	35

Boom, Attachments, and Upper Structure

■ Boom

Design — Five section, formed construction of extra high tensile steel consisting of one base section and four telescoping sections. The two plate design of each section has multiple longitudinal bends for superior strength. Each telescoping section extends independently by means of one double-acting, single stage hydraulic cylinder with integrated holding valves.

Boom

- 38–140 ft (11.6–42.7m) five section boom
- Three boom extend modes (EM1 through EM3), controlled from the operator's cab, provide superior capacities by varying the extension of the telescoping sections:
 - EM1 extends to 140.0 ft (42.7m)
 - EM2 extends to 115.8 ft (35.3m)
 - EM3 extends to 76.5 ft (23.3m)
- Mechanical boom angle indicator
- Maximum tip height for each extend mode is:
 - EM1 is 149 ft 7 in (45.6m)
 - EM2 is 125 ft 9 in (38.3m)
 - EM3 is 87 ft 1 in (26.5m)

Boom Wear Pads

- Wear pads with Teflon inserts that self-lubricate the boom sections
- Bottom wear pads are universal for all boom sections
- Top wear pads are universal for all boom sections

Boom Head

- Five 16.5 in (41.9cm) root diameter nylon sheaves to handle up to ten parts of line
- Easily removable wire rope guards
- Rope dead end lugs on each side of the boom head
- Boom head is designed for quick-reeve of the hook block

Boom Elevation

- One double acting hydraulic cylinder with integral holding valve
- Boom elevation: -3° to 80°

Auxiliary Lifting Sheave — Optional

- Single 16.5 in (41.9m) root diameter nylon sheave
- Easily removable wire rope guards
- Does not affect erection of the fly or use of the main head sheaves

Hook Blocks and Balls — Optional

- 40 ton (36.3mt) 3 sheave quick-reeve hook block with safety latch
- 40 ton (36.3mt) 4 sheave quick-reeve hook block with safety latch
- 60 ton (54.4mt) 4 sheave quick-reeve hook block with safety latch
- 80 ton (72.5mt) 5 sheave quick-reeve hook block with safety latch
- 90 ton (80.0mt) 6 sheave quick-reeve hook block with safety latch
- 8.5 ton (7.7mt) swivel and non-swivel hook balls with safety latch
- 10 ton (9.1mt) swivel and non-swivel hook balls with safety latch

Fly — Optional

- 35 ft (10.7m) one piece lattice fly, stowable, offsettable to 2° , 15° , 30° , and 45° . Maximum tip height is 184 ft 2 in (56.1m).
- 35 ft–58 ft (10.7–17.7m) two piece bi-fold lattice fly, stowable, offsettable to 2° , 15° , 30° , and 45° . Maximum tip height is 206 ft 8 in (63.0m).

Fly Extensions — Optional

- One 16 ft (4.9m) lattice extension, equipped with two 16.5 in (41.9cm) root diameter nylon sheaves, to be mounted between the boom head and fly options. Maximum tip height is 222 ft 4 in (67.8m).
- Two 16 ft (4.9m) lattice extensions, one equipped with two 16.5 in (41.9cm) root diameter nylon sheaves, to be mounted between the boom head and fly options. Maximum tip height is 238 ft 2 in (72.6m). Minimum of 19,200 lb (8.8t) of counterweight required.

■ Operator's Cab and Controls

Environmental Cab – Fully enclosed, one person cab of galvanneal steel structure with acoustical insulation

Equipped with:

- Tinted and tempered glass windows
- Extra—large fixed front window with windshield wiper and washer
- Swing up roof window with windshield wiper and washer
- Sliding left side door with large fixed window
- Sliding rear and right side windows for ventilation
- Six way adjustable, cushioned seat with seat belt and storage compartment
- Diesel fired warm—water heater with air ducts for front windshield defroster and cab floor
- Defroster fan for the front window
- Bubble level
- Circulating fan
- Adjustable sun visor
- Dome light
- Cup holder
- Fire extinguisher
- Left side viewing mirror
- Two position travel swing lock
- AM/FM radio

Air Conditioning – Optional – Integral with cab heating system utilizing the same ventilation outlets

Engine Dependant Warm—Water Heater – Optional – With air ducts for front windshield defroster and cab floor

Steering Column – Pedestal type with tilt and telescope functions for operator comfort. Column includes the following controls and indicators:

Left and right levers include:

- Horn button
 - Turn signal switch
 - Driving light switch
 - Transmission direction switch
- Panel mounted switches for:
- Travel park brake
 - Steer mode selector
 - 2/4 wheel drive/range selector

- Transmission gear selector
 - Hazard flasher
- Panel mounted indicator/warning lights for:
- Transmission temperature
 - Service brake
 - Turn signals
 - Rear wheel offset
 - Emergency steer – optional

Armrest Controls – Two dual axis hydraulic joystick controllers or optional single axis hydraulic controllers for:

- Cab heater and A/C Controls
- Swing
- Boom hoist
- Main rear winch
- Auxiliary front winch – optional
- Drum rotation indication
- Drum rotation indicator activation switch
- Winch high/low speed and disable switch(es)
- Warning horn button
- Swing park brake
- Engine throttle lock

Outrigger Controls – Hand held control box with umbilical cord gives the operator the freedom to view operation while setting the outriggers.

Foot Controls

- Boom telescope
- Swing brake
- Engine throttle
- Service brake

Right Front Console – Controls and indicators for:

- | | |
|-------------------------------------|---|
| • Engine ignition | • 12 volt power connections |
| • Engine throttle lock | • E—stop switch |
| • Function disable | • Ignition switch on indicator light |
| • Front windshield wiper and washer | • Boom floodlight's – optional |
| • Cab floodlights | • Rotating beacon/Strobe light – optional |
| • Warning horn | • Third wrap set and activate switches – optional |
| • Console dimmer switch | |
| • Bubble level | |

Cab Instrumentation — Ergonomically positioned, digital instrumentation for crane operation including:

- Tachometer
- Engine water temperature
- Fuel level
- Hydraulic oil temperature
- Stop engine
- Check engine
- Wait to start
- Diesel exhaust fluid (DEF) level⁽¹⁾
- Engine air filter high restriction light⁽¹⁾
- Regeneration light⁽¹⁾
- Regeneration inhibit switch⁽¹⁾
- Regeneration initiate switch⁽¹⁾
- High exhaust temperature light⁽¹⁾
- Regeneration disabled light⁽¹⁾
- Swing park brake light
- Engine speed
- Engine oil pressure
- Battery voltage
- Fuel rate (gal/hr)
- Engine load
- Engine Diagnostics

⁽¹⁾ (Tier 4f / Stage IV engine only)

Camera Display — Located on dash console

- Displays right side of upper
- Displays main and auxiliary winches
- Displays rear view

Diagnostic Center — Located behind the operator's seat.

- Engine diagnostic
- RCL CANBUS diagnostic
- Crane Controller USB diagnostic
- RCL controller USB diagnostic

Link-Belt Pulse — The Link-Belt in-house designed, total crane operating system that utilizes the display as a readout and operator interface for the following systems:

- **Rated capacity limiter** — LCD graphic audio — visual warning system integrated into the dash with anti — two block and function limiter. Operating data includes:
 - Crane configuration
 - Boom length and angle
 - Boom head height
 - Allowed load and % of allowed load
 - RCL light bar
 - Boom angle
 - Radius of load
 - Actual load
 - Wind speed
 - Highlighted unit of measurement on working screen
 - Active pin/latch status
 - Telescope operation displayed in real time
 - Outrigger position sensing
 - Drum rotation direction indication
 - Third wrap indicator
 - Diagnostics
 - Operator settable alarms (include):
 - Maximum and minimum boom angles
 - Maximum tip height
 - Maximum boom length
 - Swing left/right positions
 - Operator defined area (imaginary plane)
- **Extend control module (ECM)**
 - Controls the extend modes
 - Diagnostics

- **Internal RCL Light Bar** — Visually informs the operator when crane is approaching maximum load capacity with a series of green, yellow, and red lights.
- **Telematics** — Cellular based data logging and monitoring system that provides:
 - Location and operational settings
 - Routine maintenance
 - Crane and engine monitoring
 - Diagnostic and fault codes

Integrated Third Wrap Indicator — Optional — Link-Belt Pulse color display visually and audibly warns the operator when the wire rope is on the first/bottom layer and when the wire rope is down to the last three wraps.

Integrated Third Wrap Function Kickout — Optional — Link—Belt Pulse color display visually and audibly warns the operator when the wire rope is on the first/bottom layer and provides a function kickout when the wire rope is down to the last three wraps.

External RCL Light Bar — Optional — Visually informs the ground crew when crane is approaching maximum load capacity with a series of green, yellow, and red lights.

■ Swing

Motor/Planetary — Bi—directional hydraulic swing motor mounted to a planetary reducer for 360° continuous smooth swing at 1.9 rpm

Swing Park Brake — 360°, electric over hydraulic, (spring applied/hydraulic released) multi—disc brake mounted on the speed reducer. Operated by a switch from the operator's cab.

Swing Brake — 360°, foot operated, hydraulic applied disc brake mounted to the speed reducer

Swing Lock — Two—position swing lock (boom over front or rear) operated from the operator's cab

360° Positive Swing Lock — Optional — Meets New York City requirement

■ Electrical

Swing Alarm — Audio warning device signals when the upper is swinging.

Lights

- Two LED working lights on front of the cab
- One amber strobe beacon on top of the cab
- One rotating amber beacon on top of the cab — optional
- One LED working light on top of cab — optional
- Boom floodlight — Single — optional
- Boom floodlight — Dual — optional
- Boom floodlight — High intensity remote controlled — optional

■ Load Hoist System

Load Hoist Performance

Main (Rear) and Auxiliary (Front) Winches – 3/4 in (19mm) Rope										
Layer	Maximum Line Pull		Normal Line Speed		High Line Speed		Layer		Total	
	lb	kN	ft/min	m/min	ft/min	m/min	ft	m	ft	m
1	16,880	75.09	172	52.4	341	104.0	114	34.7	114	34.7
2	15,519	69.03	187	57.0	371	113.1	124	37.8	238	72.5
3	14,362	63.89	202	61.6	401	122.2	134	40.8	372	113.4
4	13,365	59.45	217	66.1	430	131.1	144	43.9	516	157.3
5	12,497	55.59	232	70.7	460	140.2	154	46.9	670	204.2
6	---	---	---	---	---	---	164	50.0	834	254.2

Wire Rope Application		Diameter		Type	Maximum Permissible Load	
		in	mm		lb	kg
Main (Rear) Winch	Standard	3/4	19	37x7 rotation resistant – right lang lay (Type KC)	16,000	7 257.5
	Optional	3/4	19	4 strand, low torque, right regular lay (Type GC)	22,400	10 160.5
	Optional	3/4	19	34x7 rotation resistant – right regular lay (Type ZB)	15,600	7 076.1
Auxiliary (Front) Winch	Standard	3/4	19	37x7 rotation resistant – right lang lay (Type KC)	16,000	7 257.5
	Optional	3/4	19	4 strand, low torque, right regular lay (Type GC)	22,400	10 160.5
	Optional	3/4	19	34x7 rotation resistant – right regular lay (Type ZB)	15,600	7 076.1

2M Main and Optional Auxiliary Winches

- Axial piston, full and half displacement (2–speed) motors driven through planetary reduction unit for positive control under all load conditions.
- Grooved lagging
- Power up/down mode of operation
- Hoist drum cable follower – optional
- Drum rotation indicator
- Drum diameter: 16 in (40.6cm)
- Rope length:
 - Main: 730 ft (222.5m)
 - Auxiliary: 500 ft (152.4m) or 730 ft (222.5m)
- Maximum rope storage: 834 ft (254.2m)
- Terminator style socket and wedge

■ Hydraulic System

Counterbalance Valves – All hoist motors, boom extend cylinders, and boom hoist cylinders are equipped with counterbalance valves to provide load lowering and prevents accidental load drop when hydraulic power is suddenly reduced.

Hydraulic Oil Coolers – One carrier mounted cooler removes heat from the hydraulic oil. Remote mounted on right side of the carrier.

■ Counterweight

Standard – Total of 19,200 lb (8.8t) counterweight consisting of two counterweights pinned to the upper with capacities for:

- 0 lb (0t) counterweight*
- 9,600 lb (4.4t) counterweight
- 19,200 lb (8.8t) counterweight

Optional – 9,600 lb (4.4t) in addition to standard counterweight for a total of 28,800 lb (13.2t) counterweight with capacities for:

- 0 lb (0t) counterweight*
- 9,600 lb (4.4t) counterweight
- 19,200 lb (8.8t) counterweight
- 28,800 lb (13.2t) counterweight*

* Travel speed limited to 5 mph.

Optional – Hydraulic counterweight removal activated by a hand–held controller with enough cable to access the pins on each side of the counterweights.

Carrier

General

- 10 ft 9 in (3.28m) wide
- 14 ft 4 in (4.37m) wheelbase (centerline of first axle to centerline of second axle)

Frame – Box–type, torsion resistant, welded construction made of high tensile steel. Equipped with front and rear towing and tie–down lugs, tow connections, and access ladders.

Outriggers

Boxes – Two double box, front and rear welded to carrier frame

Beams and Jacks – Four single stage beams with Confined Area Lifting Capacities (CALC™) provide selectable outrigger extensions of full, intermediate, and retracted. Hydraulically controlled from the operator's cab with integral check valves.

Pontoons – Four lightweight, quick release, 23.5 x 23.5 in (59.7 x 59.7cm), steel pontoons with contact area of 460 in² (2 968cm²) can be stored for road travel in storage racks on the carrier.

Main Jack Reaction – 108,000 lb (48 988kg) force and 235 psi (1 620kPa) ground bearing pressure

Steering and Axles

Steering – Four independent modes consisting of two wheel front, two wheel rear, four wheel, and crab. Each mode is controlled from the steering wheel and is selected by a switch in the operator's cab.

Drive – Two modes: 4 x 2 and 4 x 4 for off highway travel

Axle 1 – Steered, non–driven for 4 x 2 and steered, driven for 4 x 4

Axle 2 – Steered, driven

Suspension

Front – Rigid mount to the carrier frame

Rear – The rear axle is suspended on the oscillation cylinders with motion of the axle controlled by a four bar linkage system. The oscillation cylinders lockout when the upper structure rotates 2.5° past centerline.

- Hydro–gas rear suspension – optional

Ride Height Adjustment – Suspension can be lowered for transport using a hand–held controller from level ground.

Tires and Wheels

Front and Rear – Four (single) 29.5 x 25–28 ply rating, earthmover type tires on steel disc wheels

- Spare tires and wheels – optional

Brakes

Service – Full hydraulic, dual circuit, disc type brakes on all wheel ends

Parking/Emergency – Spring applied type, acting on front axle

Electrical

Two batteries provide 12 volt starting and operation

Lights

- Front lighting includes two main headlights and two parking/directional indicators.
- Side lighting includes two parking/directional indicators per side.
- Rear lighting includes two parking/directional indicators, two parking/brake lights, and two reversing lights.
- Other equipment includes hazard/warning system, cab light, instrument panel light, and signal horn.

Engine

Specification	Cummins QSB	
Numbers of Cylinders	6	6
Cycle	4	4
Emissions Compliance Level:	Tier 4f/Stage IV ⁽¹⁾	Tier 3/Stage IIIA ⁽²⁾
Bore and Stroke: inch (mm)	4.21 x 4.88 (107 x 124)	4.21 x 4.88 (107 x 124)
Piston Displacement: in ³ (L)	408 (6.7)	408 (6.7)
Max. Brake Horsepower: hp (kW)	270 (201) @ 2,000 rpm	270 (201) @ 2,000 rpm
	260 (194) @ 2,200 rpm	260 (194) @ 2,200 rpm
Peak Torque: ft lb (Nm)	730 (990) @ 1,500 rpm	730 (990) @ 1,500 rpm
Electric/starting systems: volts	12/12	12/12
Alternator: amps	160	160
Crankcase Capacity: qt (L)	15 (14.2)	15 (14.2)
<ul style="list-style-type: none"> • Water/fuel separator w/ heater and water in fuel (WIF) sensor • 120–volt block heater – Tier 4f / Stage IV • 220–volt block heater – Tier 3 / Stage IIIA • Grid heater – 200 amp • Mechanically driven, variable speed, engine controlled, viscous fan clutch • ⁽¹⁾ Can only be sold and/or operated where Tier 4f and Stage IV off–highway emission standards are accepted. • ⁽²⁾ Can only be sold and/or operated where Tier 3 and Stage IIIA off–highway emission standards are accepted. 		

Transmission

Powershift – Three speed with high/low range for 6 forward and 6 reverse gears. Front axle disconnect for two or four wheel drive. Front axle disconnects in high range.

■ Fuel Tank

One 75 gallon (283.9L) capacity tank
 Diesel Exhaust Fluid (DEF) tank

- One 5 gal (18.9L) capacity tank

■ Hydraulic System

All functions are hydraulically powered allowing positive precise control with independent or simultaneous operation of all functions.

Main Pumps

- One two section fixed displacement gear pump for the front/rear winches and boom hoist/telescope circuits.
- One two section fixed displacement gear pump for the swing/steering and outrigger/telescope/service brake/oscillation circuits.
- One two section gear pump for an additional supply to the front/rear winch circuit and the hydraulic oil cooler fan drive.
- Combined pump capacity of 138 gpm (522.4Lpm)

Hydraulic Reservoir – 153 gal (579.2L) capacity equipped with sight level gauge. Diffusers built in for deaeration.

Filtration – One 10 micron, full flow return line filter. Accessible for easy filter replacement.

■ Maximum Speed

18.4 mph (29.6 km/h)

■ Gradeability

Counterweight	Ascending		Descending		Side	
	Degrees	% Grade	Degrees	% Grade	Degrees	% Grade
0	22.0	40%	7.0	12%	3.0	5%
9,600 lbs (4.4t)	20.0	36%	18.0	32%		
19,200 lbs (8.8t)	18.0	32%	18.0	32%		
28,800 lbs (13.2t)	12.0	21%	17.0	31%		

■ Pump Drive

One pump is mounted on the engine with the rest being transmission mounted. All pumps are mechanically driven by the diesel engine.

- Front/rear winches and boom hoist/telescope pump can be disconnected with a manual pump disconnect to aid in cold weather starting.

■ Paint

Entire machine is pre-painted and oven baked with Highsolid Paint (2 part epoxy/polyester) and/or (2 part epoxy primer/2 part polyurethane top coat). Standard Link-Belt Red, Link-Belt Gray, and Gloss Black colors apply.

Axle Loads

Base crane with zero counterweight and full tank of fuel	Gross Vehicle Weight ⁽¹⁾		Upper Facing Front				Upper Facing Rear			
			Front Axles		Rear Axles		Front Axles		Rear Axles	
	lb	kg	lb	kg	lb	kg	lb	kg	lb	kg
Tier 4f / Stage IV	80,681	36 596	50,869	23 074	29,812	13 522	23,261	10 551	57,419	26 045
Tier 3 / Stage IIIA	80,863	36 679	51,151	23 202	29,446	13 356	23,544	10 679	57,053	25 879
Pintle hook, front	13	6	17	8	-5	-2	17	8	-5	-2
Pintle hook, rear	13	6	-5	-2	18	8	-5	-2	18	8
Hydro-gas suspension	56	25	20	9	36	16	20	9	36	16
Operator in cab	250	113	140	64	110	50	110	50	140	64
Hoist drum follower – main	69	31	-24	-11	93	42	93	42	-24	-11
Auxiliary winch with 500 ft (152.4m) wire rope	608	276	-74	-34	682	309	682	309	-74	-34
Hoist drum follower – auxiliary	69	31	-6	-3	75	34	75	34	-6	-3
Substitute 500 ft (152.4m) wire rope with 730 ft (222.5m) – auxiliary	288	131	-9	-4	297	135	297	135	-9	-4
Remove 730 ft (222.5m) wire rope from rear (main) winch	-931	-422	203	92	-1,134	-514	-1,134	-514	203	92
Remove 500 ft (152.4m) wire rope from front (auxiliary) winch	-643	-292	21	10	-664	-301	-664	-301	21	10
Counterweight removal	208	94	-62	-28	270	122	270	122	-62	-28
One slab of counterweight on upper	9,600	4 355	-3,356	-1 522	12,956	5 877	12,956	5 877	-3,356	-1 522
Two slabs of counterweight on upper	19,200	8 709	-6,712	-3 045	25,912	11 754	25,912	11 754	-6,712	-3 045
Three slabs of counterweight on upper	28,800	13 064	-10,068	-4 567	38,868	17 630	38,868	17 630	-10,068	-4 567
Emergency steering	255	116	39	18	216	100	216	100	39	18
360° mechanical swing lock	140	64	72	33	68	31	68	31	72	33
Air conditioning	179	81	50	23	129	59	129	59	50	23
Floodlight to front of boom base section	7	3	10	5	-3	-1	-3	-1	10	5
Fly mounting brackets to boom base section for fly options	176	80	239	108	-63	-29	-63	-29	239	108
35 ft (10.67m) offsettable fly – stowed	1,591	722	2,576	1 168	-984	-446	-984	-446	2,576	1 168
35–58 ft (10.67–17.68m) offsettable fly – stowed	2,263	1 026	3,257	1 477	-994	-451	-994	-451	3,257	1 477
Auxiliary lifting sheave	110	50	304	138	-194	-88	-194	-88	304	138
90 ton (80.0mt) 6–sheave hook block at bumper	1,554	705	2,358	1 070	-804	-365	-804	-365	2,358	1 070
80 ton (72.5mt) 5–sheave hook block at bumper	1,406	638	2,134	968	-728	-330	-728	-330	2,134	968
60 ton (54.4mt) 4–sheave hook block at bumper	1,109	503	1,683	763	-574	-260	-574	-260	1,683	763
10 ton (9.1mt) hook ball at bumper	550	250	834	378	-284	-129	-284	-129	834	378
8.5 ton (7.7mt) hook ball at bumper	360	163	546	248	-186	-84	-186	-84	546	248
90 ton (80.0mt) 6–sheave hook block at boom head	1,554	705	4,138	1 877	-2,584	-1 172	-2,584	-1 172	4,138	1 877
80 ton (72.5mt) 5–sheave hook block at boom head	1,406	638	3,744	1 698	-2,338	-1 061	-2,338	-1 061	3,744	1 698
60 ton (54.4mt) 4–sheave hook block at boom head	1,109	503	2,953	1 340	-1,844	-836	-1,844	-836	2,953	1 340
10 ton (9.1mt) hook ball at boom head	550	250	1,465	665	-915	-415	-915	-415	1,465	665
8.5 ton (7.7mt) hook ball at boom head	360	163	959	435	-599	-272	-599	-272	959	435

Tire	Maximum Allowable Axle Load @ 20 mph (32.2km/h)
29.5 x 25 (28–PR)	55,000 lb (24 948kg)

⁽¹⁾ Adjust gross vehicle weight and axle loading according to component weight.

Note: All weights are $\pm 3\%$.

General Dimensions

Tier 4f / Stage IV

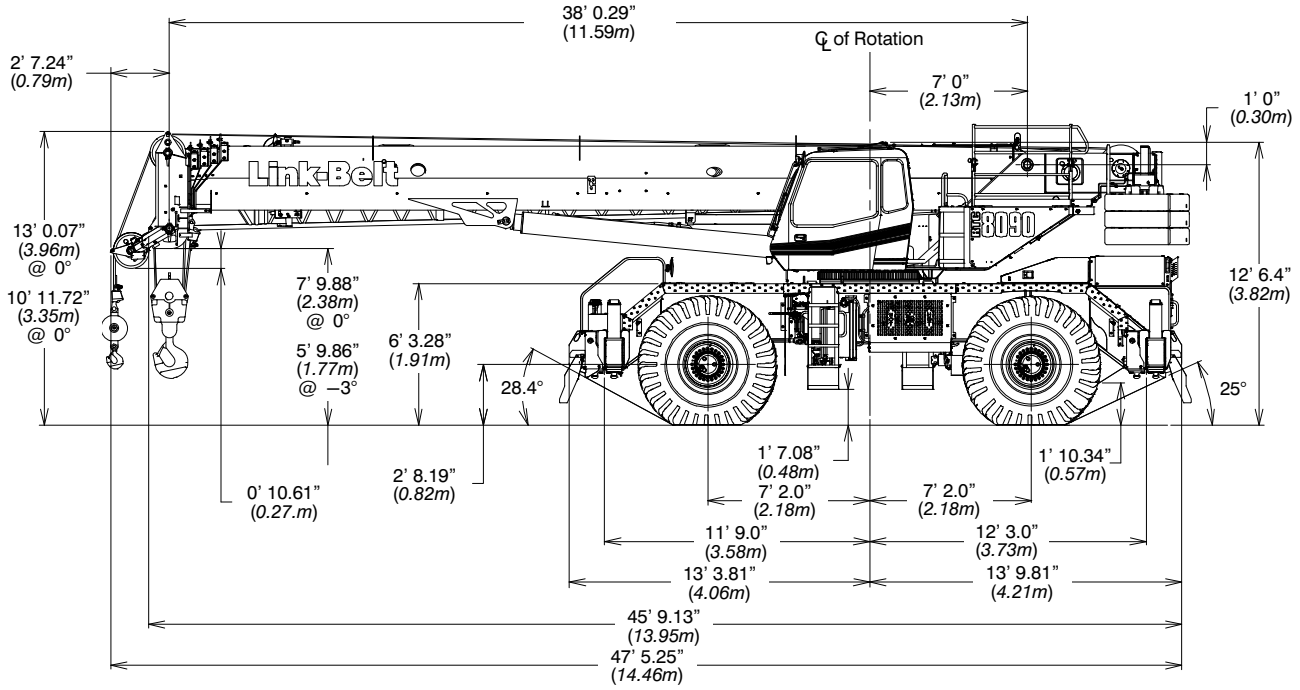

Turning Radius – Front Wheel (4x2) Steering	English	Metric
Wall to wall over carrier	48' 3"	14.71m
Wall to wall over boom attachment	60' 1"	18.31m
Curb to curb	46' 8"	14.22m
Centerline of tire	45' 3"	13.79m

Turning Radius – All Wheel (4x4) Steering	English	Metric
Wall to wall over carrier	27' 10"	8.48m
Wall to wall over boom attachment	38' 11"	11.86m
Curb to curb	26' 0"	7.92m
Centerline of tire	24' 6"	7.47m

Tail Swing	English	Metric
With counterweight	14' 2"	4.32m
Without counterweight	13' 2"	4.01m

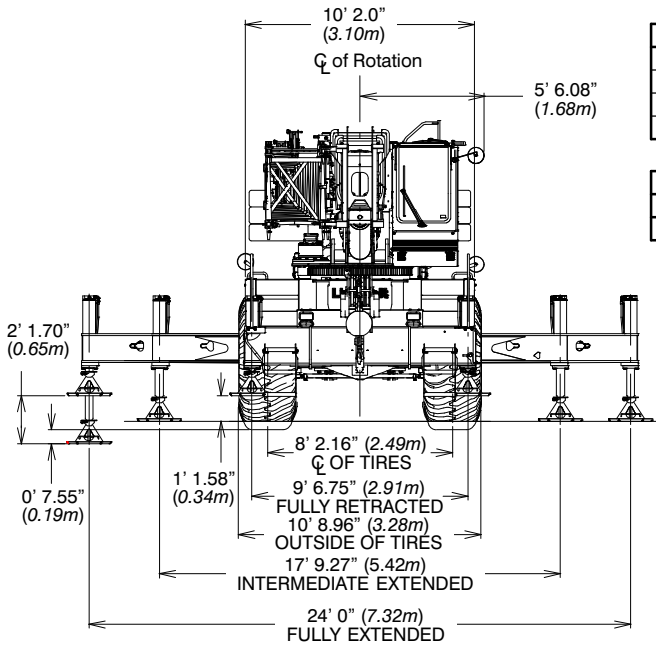

Not To Scale

General Dimensions

Tier 3 / Stage IIIA

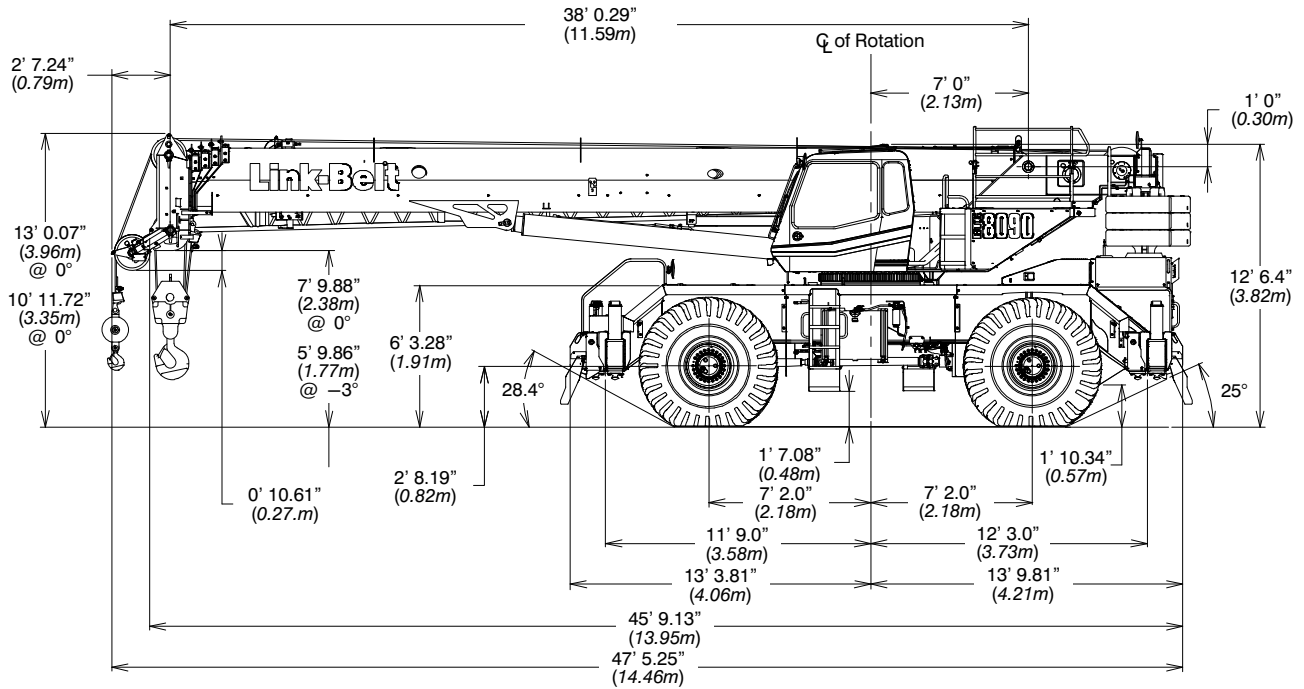

Turning Radius – Front Wheel (4x2) Steering	English	Metric
Wall to wall over carrier	48' 3"	14.71m
Wall to wall over boom attachment	60' 1"	18.31m
Curb to curb	46' 8"	14.22m
Centerline of tire	45' 3"	13.79m

Turning Radius – All Wheel (4x4) Steering	English	Metric
Wall to wall over carrier	27' 10"	8.48m
Wall to wall over boom attachment	38' 11"	11.86m
Curb to curb	26' 0"	7.92m
Centerline of tire	24' 6"	7.47m

Tail Swing	English	Metric
With counterweight	14' 2"	4.32m
Without counterweight	13' 2"	4.01m

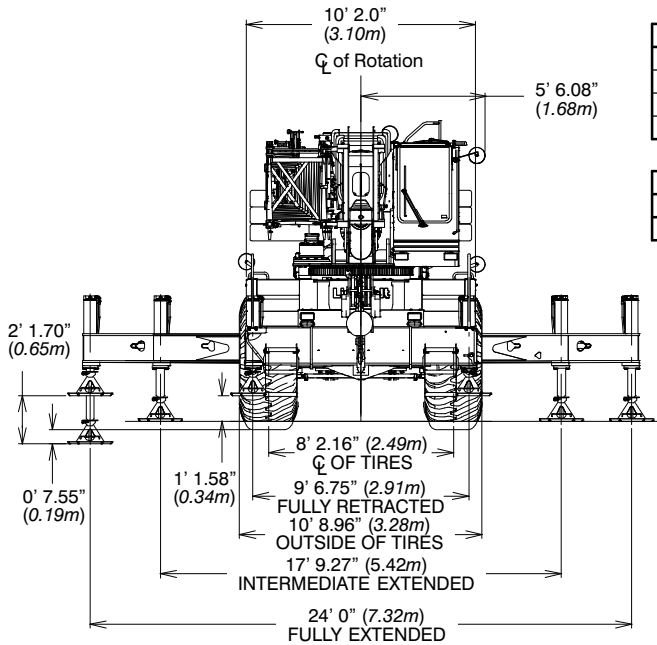

Not To Scale

Working Range Diagram

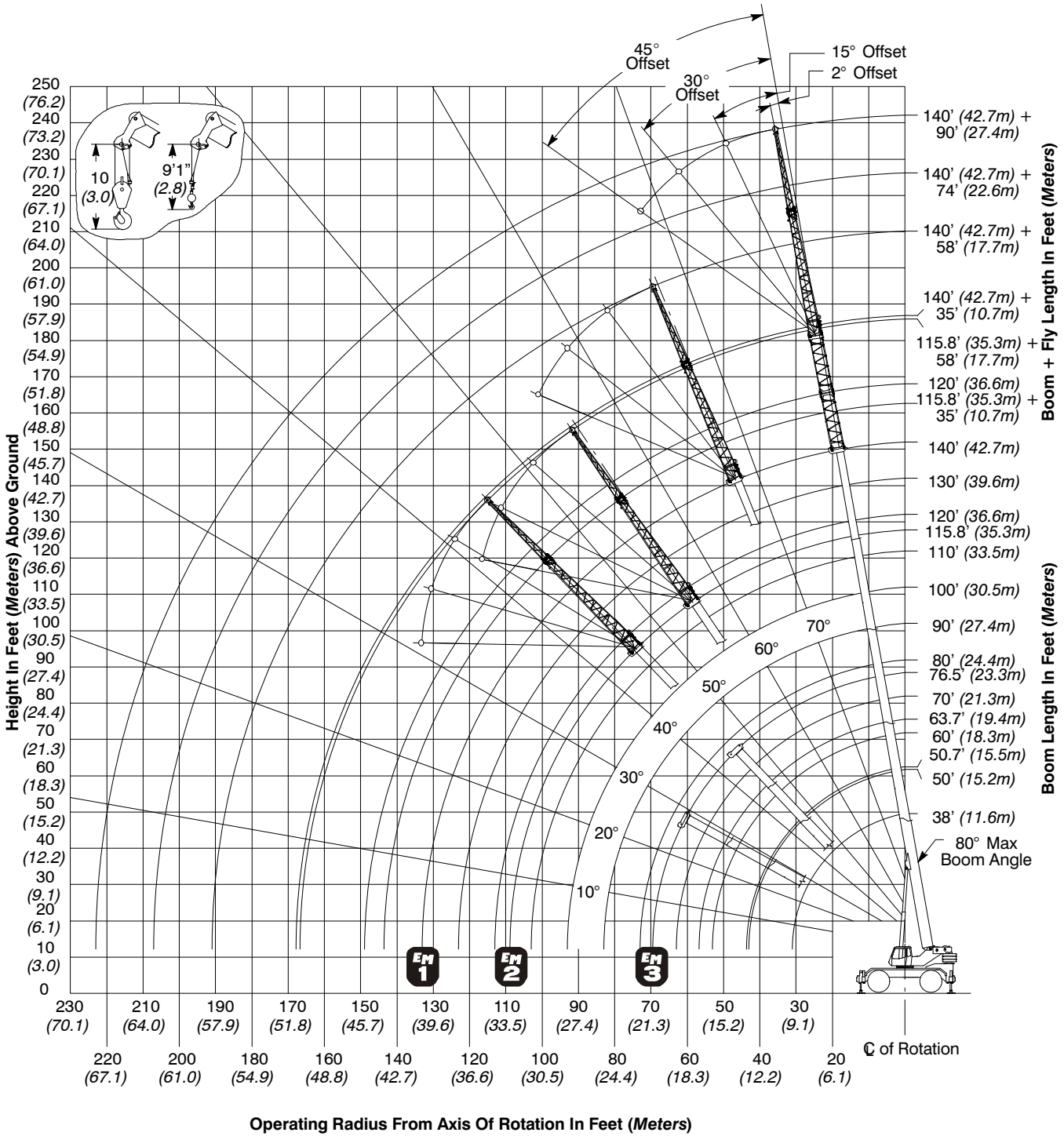

Boom Extend Modes

Boom Length		Section Length			
ft	m	T4	T3	T2	T1
50	15.2	50%			
60	18.3	91%			
70	21.3	100%	31%		
80	24.4	100%	71%		
90	27.4	100%	100%	11%	
100	30.5	100%	100%	49%	
110	33.5	100%	100%	88%	
120	36.6	100%	100%	100%	25%
130	39.6	100%	100%	100%	63%
140	42.7	100%	100%	100%	100%

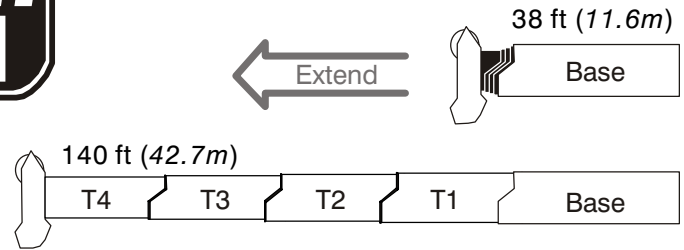

Boom Length		Section Length			
ft	m	T4	T3	T2	T1
50	15.2	0%	48%		
60	18.3	0%	88%		
70	21.3	0%	100%	27%	
80	24.4	0%	100%	65%	
90	27.4	0%	100%	100%	4%
100	30.5	0%	100%	100%	41%
115.8	35.3	0%	100%	100%	100%

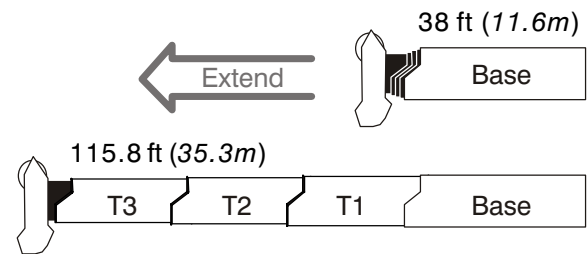

Boom Length		Section Length			
ft	m	T4	T3	T2	T1
50.7	15.5	0%	51%		
63.7	19.4	0%	51%	50%	
76.5	23.3	0%	51%	50%	48%

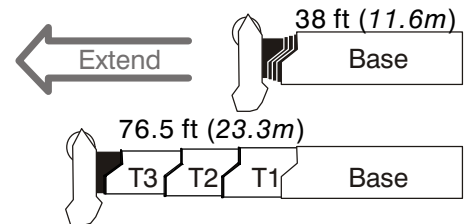

Main Boom Lift Capacity Charts – Imperial

19,200 lb Counterweight – Fully Extended Outriggers – 360° Rotation (All Capacities Are Listed In Pounds)												
Radius (ft)	Boom Length (ft)											Radius (ft)
	38	50	60	70	80	90	100	110	120	130	140	
8	180,000*											8
10	160,000	152,000	117,900	70,800								10
12	138,000	138,600	108,800	70,800	85,100							12
15	109,500	111,700	106,500	70,800	78,400	54,200						15
20	80,100	82,400	82,800	63,500	76,500	52,000	49,100	27,200				20
25	62,000	64,300	64,800	54,800	64,300	45,600	45,200	36,300**	28,000	26,900		25
30	49,700	52,000	52,600	47,800	52,100	40,600	42,200	35,900**	28,000	26,500	24,400	30
35		42,900	44,100	42,500	42,800	36,500	38,300	35,500**	28,000	26,300	24,100	35
40		34,300	34,600	35,000	35,100	33,000	34,700	33,400**	28,000	26,100	24,000	40
45			28,100	28,400	28,500	28,500	28,100	27,500**	26,100	25,900	23,800	45
50			23,200	23,600	23,700	23,800	23,300	23,800	24,100	24,600	23,700	50
55			19,000	20,800	21,300	20,000	21,300	21,700	21,300	20,900	20,500	55
60				18,400	18,800	18,300	18,800	18,700	18,300	17,900	17,600	60
65					16,300	16,500	16,400	16,300	15,900	15,500	15,100	65
70					14,300	14,500	14,400	14,300	13,900	13,500	13,200	70
75						12,800	12,800	12,700	12,300	12,000	11,600	75
80						11,400	11,300	11,200	10,900	10,500	10,200	80
85							10,100	10,000	9,700	9,300	9,000	85
90							9,000	8,900	8,600	8,200	7,900	90
95								8,000	7,700	7,300	7,000	95
100								7,100	6,800	6,500	6,200	100
105								4,200**	6,100	5,700	5,400	105
110									5,400	5,100	4,700	110
115										4,500	4,200	115
120										3,900	3,600	120
125											3,100	125
130											2,700	130

* Special Conditions Or Wire Rope Required

** Boom Mode EM2, 115.8 ft

This information is not for crane operation. Operator must refer to the in-cab information for crane operation. Rated lifting capacities shown on fully extended outriggers do not exceed 85% of the tipping loads and on tires do not exceed 75% of the tipping loads.

19,200 lb Counterweight – On Tires – Stationary – Boom Centered Over Front Between Tire Tracks (All Capacities Are Listed In Pounds)									
Radius (ft)	Boom Length (ft)								Radius (ft)
	38	50	60	70	80	90	100	110	
15	54,700								15
20	43,300								20
25	33,000	36,200							25
30	23,400	26,500	27,900						30
35		20,300	21,700	22,300					35
40		15,900	17,300	17,900	18,300				40
45			14,000	14,700	15,100	15,200			45
50			11,600	12,200	12,600	12,700	12,700		50
55				10,200	10,700	10,900	10,800	10,700	55
60				8,600	9,000	9,200	9,200	9,100	60
65					7,700	7,900	7,800	7,800	65
70					6,600	6,800	6,700	6,700	70
75						5,800	5,800	5,700	75
80						5,000	4,900	4,900	80
85							4,200	4,200	85
90							3,600	3,500	90
95								3,000	95
100								2,500	100

This information is not for crane operation. Operator must refer to the in-cab information for crane operation. Rated lifting capacities shown on fully extended outriggers do not exceed 85% of the tipping loads and on tires do not exceed 75% of the tipping loads.

19,200 lb Counterweight – On Tires – Pick & Carry (Creep) – Boom Centered Over Front (All Capacities Are Listed In Pounds)									
Radius (ft)	Boom Length (ft)								Radius (ft)
	38	50	60	70	80	90	100	110	
15	52,200								15
20	40,100								20
25	31,700	34,100							25
30	23,400	26,500	27,900						30
35		20,300	21,700	22,300					35
40		15,900	17,300	17,900	18,300				40
45			14,000	14,700	15,100	15,200			45
50			11,600	12,200	12,600	12,700	12,700		50
55				10,200	10,700	10,900	10,800	10,700	55
60				8,600	9,000	9,200	9,200	9,100	60
65					7,700	7,900	7,800	7,800	65
70					6,600	6,800	6,700	6,700	70
75						5,800	5,800	5,700	75
80						5,000	4,900	4,900	80
85							4,200	4,200	85
90							3,600	3,500	90
95								3,000	95
100								2,500	100

19,200 lb Counterweight – On Tires – Stationary – 360° Rotation (All Capacities Are Listed In Pounds)									
Radius (ft)	Boom Length (ft)								Radius (ft)
	38	50	60	70	80	90	100	110	
15	33,700								15
20	20,400								20
25	13,200	15,900							25
30	8,700	11,400	12,700						30
35		8,200	9,500	10,200					35
40		5,900	7,200	7,800	8,200				40
45			5,500	6,100	6,500	6,700			45
50			4,100	4,700	5,100	5,300	5,200		50
55				3,600	4,000	4,100	4,100	4,100	55
60				2,700	3,000	3,200	3,200	3,100	60
65					2,300	2,500	2,400	2,400	65
70					1,600	1,800	1,800	1,700	70
75						1,200	1,200	1,100	75

This information is not for crane operation. Operator must refer to the in-cab information for crane operation. Rated lifting capacities shown on fully extended outriggers do not exceed 85% of the tipping loads and on tires do not exceed 75% of the tipping loads.

28,800 lb Counterweight – Fully Extended Outriggers – 360° Rotation
 (All Capacities Are Listed In Pounds)

Radius (ft)	Boom Length (ft)										Radius (ft)	
	38	50	60	70	80	90	100	110	120	130		140
8	180,000*											8
10	160,000	152,000	117,900	70,800								10
12	139,600	138,600	108,800	70,800	85,100							12
15	116,300	118,400	106,500	70,800	78,400	54,200						15
20	85,300	87,500	87,900	63,500	76,500	52,000	49,100	27,200				20
25	66,200	68,500	69,000	54,800	68,500	45,600	45,200	36,300**	28,000	26,900		25
30	53,200	55,500	56,100	47,800	55,700	40,600	42,200	35,900**	28,000	26,500	24,400	30
35		46,200	46,800	42,500	46,400	36,500	38,300	35,500**	28,000	26,300	24,100	35
40		39,600	40,100	38,100	39,300	33,000	34,900	33,400**	28,000	26,100	24,000	40
45			34,200	34,500	33,800	30,100	32,100	30,300**	26,100	25,900	23,800	45
50			28,500	28,900	28,900	27,600	28,500	27,900**	24,100	25,200	23,700	50
55			23,700	24,600	24,700	24,700	24,300	23,800**	22,300	23,500	23,600	55
60				21,100	21,200	21,300	20,900	20,400**	20,700	21,900	21,700	60
65					18,500	18,500	18,600	18,900	19,300	19,300	18,900	65
70					17,300	16,200	17,500	17,700	17,400	17,000	16,600	70
75						14,900	15,900	15,700	15,400	15,000	14,700	75
80						14,100	14,200	14,100	13,700	13,400	13,000	80
85							12,800	12,700	12,400	12,000	11,700	85
90							11,600	11,500	11,200	10,800	10,500	90
95								10,400	10,100	9,700	9,400	95
100								9,400	9,100	8,700	8,400	100
105								6,300**	8,200	7,900	7,600	105
110									7,400	7,100	6,800	110
115										6,400	6,100	115
120										5,800	5,500	120
125											4,900	125
130											4,400	130

* Special Conditions Or Wire Rope Required

** Boom Mode EM2, 115.8 ft

This information is not for crane operation. Operator must refer to the in-cab information for crane operation. Rated lifting capacities shown on fully extended outriggers do not exceed 85% of the tipping loads and on tires do not exceed 75% of the tipping loads.

Fly Attachment Lift Capacity Charts – Optional

19,200 lb Counterweight – Fully Extended Outriggers – 360° Rotation (All Capacities Are Listed In Pounds)									
140 ft Main Boom Length 2° Fly Offset					140 ft Main Boom Length 15° Fly Offset				
Radius (ft)	Fly Length (ft)				Radius (ft)	Fly Length (ft)			
	35	58	74	90		35	58	74	90
35	12,100				35				
40	12,100				40				
45	12,100	8,500			45	11,500			
50	12,100	8,400	6,600		50	11,400			
55	12,100	8,300	6,600	5,200	55	11,200			
60	12,100	8,100	6,600	5,200	60	11,000	7,200		
65	11,900	8,000	6,600	5,200	65	10,800	7,000	6,300	
70	11,700	7,800	6,600	5,200	70	10,600	6,800	6,000	4,800
75	11,500	7,700	6,600	5,100	75	10,400	6,700	5,700	4,500
80	10,900	7,500	6,400	4,800	80	10,200	6,500	5,400	4,200
85	9,600	7,300	6,000	4,500	85	10,000	6,300	5,100	4,000
90	8,500	7,100	5,700	4,200	90	9,100	6,200	4,900	3,700
95	7,600	6,900	5,400	4,000	95	8,100	6,000	4,600	3,500
100	6,700	6,700	5,100	3,700	100	7,200	5,900	4,400	3,300
105	6,000	6,400	4,900	3,500	105	6,400	5,700	4,200	3,100
110	5,300	5,700	4,700	3,300	110	5,700	5,600	4,100	3,000
115	4,700	5,100	4,500	3,200	115	5,000	5,500	3,900	2,800
120	4,100	4,500	4,300	3,000	120	4,400	5,100	3,700	2,700
125	3,600	4,000	3,900	2,800	125	3,900	4,500	3,600	2,500
130	3,100	3,600	3,500	2,700	130	3,400	4,000	3,500	2,400
135	2,700	3,100	3,000	2,500	135	3,000	3,600	3,300	2,300
140	2,300	2,700	2,600	2,400	140	2,500	3,100	3,000	2,200
145	2,000	2,400	2,300	2,200	145	2,200	2,700	2,600	2,100
150	1,700	2,000	1,900	1,900	150	1,800	2,400	2,200	2,000
155	1,400	1,700	1,600	1,600	155	1,500	2,000	1,900	1,900
160	1,100	1,400	1,300	1,300	160	1,200	1,700	1,600	1,600
165	800	1,200	1,000	1,000	165	900	1,400	1,300	1,300
170		900			170		1,100	1,000	1,000

This information is not for crane operation. Operator must refer to the in-cab information for crane operation. Rated lifting capacities shown on fully extended outriggers do not exceed 85% of the tipping loads and on tires do not exceed 75% of the tipping loads.

19,200 lb Counterweight – Fully Extended Outriggers – 360° Rotation (All Capacities Are Listed In Pounds)									
140 ft Main Boom Length 30° Fly Offset					140 ft Main Boom Length 45° Fly Offset				
Radius (ft)	Fly Length (ft)				Radius (ft)	Fly Length (ft)			
	35	58	74	90		35	58	74	90
40					40				
45					45				
50					50				
55	10,000				55				
60	9,800				60				
65	9,700				65	8,800			
70	9,500				70	8,800			
75	9,400	5,700	4,600		75	8,700			
80	9,200	5,600	4,400	3,600	80	8,600			
85	9,100	5,500	4,200	3,400	85	8,600	4,900	3,700	
90	9,000	5,400	4,100	3,200	90	8,500	4,900	3,500	2,900
95	8,500	5,300	3,900	3,000	95	8,400	4,800	3,400	2,700
100	7,600	5,200	3,700	2,900	100	7,900	4,800	3,300	2,600
105	6,800	5,100	3,600	2,700	105	7,000	4,700	3,200	2,400
110	6,000	5,000	3,500	2,600	110	6,200	4,700	3,100	2,300
115	5,300	4,900	3,300	2,400	115	5,500	4,700	3,000	2,200
120	4,700	4,800	3,200	2,300	120	4,900	4,600	2,900	2,100
125	4,100	4,700	3,100	2,200	125	4,300	4,500	2,800	2,000
130	3,600	4,500	3,000	2,100	130	3,700	4,400	2,700	1,900
135	3,100	4,000	2,900	2,000	135	3,200	4,300	2,700	1,800
140	2,700	3,500	2,800	1,900	140		3,700	2,600	1,800
145	2,300	3,100	2,800	1,800	145		3,300	2,600	1,700
150	1,900	2,700	2,600	1,700	150		2,800	2,500	1,600
155	1,500	2,300	2,200	1,700	155		2,400	2,400	1,600
160		1,900	1,900	1,600	160		2,000	2,100	1,500
165		1,600	1,500	1,500	165			1,700	1,500
170		1,300	1,200	1,300	170			1,300	1,400
175		900	900	1,000	175				1,100

This information is not for crane operation. Operator must refer to the in-cab information for crane operation. Rated lifting capacities shown on fully extended outriggers do not exceed 85% of the tipping loads and on tires do not exceed 75% of the tipping loads.

28,800 lb Counterweight – Fully Extended Outriggers – 360° Rotation (All Capacities Are Listed In Pounds)									
140 ft Main Boom Length 2° Fly Offset					140 ft Main Boom Length 15° Fly Offset				
Radius (ft)	Fly Length (ft)				Radius (ft)	Fly Length (ft)			
	35	58	74	90		35	58	74	90
35	12,100				35				
40	12,100				40				
45	12,100	8,500			45	11,500			
50	12,100	8,400	6,600		50	11,400			
55	12,100	8,300	6,600	5,200	55	11,200			
60	12,100	8,100	6,600	5,200	60	11,000	7,200		
65	11,900	8,000	6,600	5,200	65	10,800	7,000	6,300	
70	11,700	7,800	6,600	5,200	70	10,600	6,800	6,000	4,800
75	11,500	7,700	6,600	5,100	75	10,400	6,700	5,700	4,500
80	11,300	7,500	6,400	4,800	80	10,200	6,500	5,400	4,200
85	11,000	7,300	6,000	4,500	85	10,000	6,300	5,100	4,000
90	10,500	7,100	5,700	4,200	90	9,700	6,200	4,900	3,700
95	10,000	6,900	5,400	4,000	95	9,400	6,000	4,600	3,500
100	9,000	6,700	5,100	3,700	100	9,000	5,900	4,400	3,300
105	8,100	6,500	4,900	3,500	105	8,500	5,700	4,200	3,100
110	7,300	6,300	4,700	3,300	110	7,700	5,600	4,100	3,000
115	6,600	6,000	4,500	3,200	115	7,000	5,500	3,900	2,800
120	6,000	5,800	4,300	3,000	120	6,300	5,300	3,700	2,700
125	5,400	5,600	4,100	2,800	125	5,700	5,100	3,600	2,500
130	4,800	5,300	3,900	2,700	130	5,100	4,900	3,500	2,400
135	4,400	4,800	3,800	2,500	135	4,600	4,700	3,300	2,300
140	3,900	4,300	3,600	2,400	140	4,100	4,600	3,200	2,200
145	3,500	3,900	3,500	2,300	145	3,700	4,200	3,100	2,100
150	3,100	3,500	3,400	2,200	150	3,300	3,800	3,000	2,000
155	2,700	3,100	3,000	2,100	155	2,900	3,400	2,900	1,900
160	2,400	2,800	2,600	2,000	160	2,500	3,100	2,800	1,800
165	2,100	2,500	2,300	1,900	165	2,200	2,700	2,600	1,700
170		2,200	2,000	1,800	170		2,400	2,300	1,600
175		1,900	1,800	1,700	175		2,100	2,000	1,600
180		1,700	1,500	1,500	180		1,800	1,700	1,500
185		1,400	1,200	1,200	185		1,500	1,400	1,400
190		1,200	1,000	1,000	190			1,200	1,200
195					195			900	900

This information is not for crane operation. Operator must refer to the in-cab information for crane operation. Rated lifting capacities shown on fully extended outriggers do not exceed 85% of the tipping loads and on tires do not exceed 75% of the tipping loads.

28,800 lb Counterweight – Fully Extended Outriggers – 360° Rotation (All Capacities Are Listed In Pounds)									
140 ft Main Boom Length 30° Fly Offset					140 ft Main Boom Length 45° Fly Offset				
Radius (ft)	Fly Length (ft)				Radius (ft)	Fly Length (ft)			
	35	58	74	90		35	58	74	90
40					40				
45					45				
50					50				
55	10,000				55				
60	9,800				60				
65	9,700				65	8,800			
70	9,500				70	8,800			
75	9,400	5,700	4,600		75	8,700			
80	9,200	5,600	4,400	3,600	80	8,600			
85	9,100	5,500	4,200	3,400	85	8,600	4,900	3,700	
90	9,000	5,400	4,100	3,200	90	8,500	4,900	3,500	2,900
95	8,800	5,300	3,900	3,000	95	8,400	4,800	3,400	2,700
100	8,500	5,200	3,700	2,900	100	8,200	4,800	3,300	2,600
105	8,200	5,100	3,600	2,700	105	8,000	4,700	3,200	2,400
110	8,000	5,000	3,500	2,600	110	7,700	4,700	3,100	2,300
115	7,300	4,900	3,300	2,400	115	7,500	4,700	3,000	2,200
120	6,600	4,800	3,200	2,300	120	6,700	4,600	2,900	2,100
125	5,900	4,700	3,100	2,200	125	6,000	4,500	2,800	2,000
130	5,300	4,500	3,000	2,100	130	5,400	4,400	2,700	1,900
135	4,800	4,400	2,900	2,000	135	4,800	4,300	2,700	1,800
140	4,300	4,300	2,800	1,900	140		4,200	2,600	1,800
145	3,800	4,200	2,800	1,800	145		4,100	2,600	1,700
150	3,300	4,100	2,700	1,700	150		4,000	2,500	1,600
155	2,900	3,700	2,600	1,700	155		3,800	2,500	1,600
160		3,300	2,600	1,600	160		3,300	2,500	1,500
165		2,900	2,500	1,500	165		2,900	2,500	1,500
170		2,500	2,500	1,500	170			2,500	1,400
175		2,200	2,200	1,400	175			2,200	1,400
180		1,800	1,800	1,400	180				1,400
185			1,500	1,400	185				1,400
190			1,300	1,300	190				1,400
195			1,000	1,100	195				

This information is not for crane operation. Operator must refer to the in-cab information for crane operation. Rated lifting capacities shown on fully extended outriggers do not exceed 85% of the tipping loads and on tires do not exceed 75% of the tipping loads.

Main Boom Lift Capacity Charts – 75% – Metric

8.8t Counterweight – Fully Extended Outriggers – 360° Rotation (All Capacities Are Listed In Kilograms)												
Radius (m)	Boom Length (m)										Radius (m)	
	11.58	15.2– 15.5	18.3– 19.4	21.3	23.32– 24.4	27.4	30.5	33.5	35.3– 36.6	39.6		42.67
2.5	80 000*											2.5
3	72 550	69 500	53 450	32 100								3
3.5	64 300	64 250	50 350	32 100								3.5
4	57 150	58 050	48 900	32 100	37 400							4
4.5	50 500	51 500	48 350	32 100	35 750	24 550						4.5
5	45 150	46 150	46 300	32 000	35 250	24 550						5
6	37 000	38 000	38 200	29 050	34 700	23 800	22 250	12 350				6
7	31 050	32 100	32 300	26 450	32 050	21 800	21 150	12 350				7
8	26 550	27 600	27 850	24 000	27 650	20 100	20 100	16 400	12 750	12 150		8
9	23 000	24 050	24 300	21 950	24 100	18 600	19 350	16 250	12 750	12 000	11 050	9
10		20 350	20 900	20 300	20 300	17 300	18 100	16 100	12 750	11 900	10 950	10
12		14 700	14 900	15 050	15 100	15 100	14 900	14 600	12 750	11 800	10 850	12
14			11 250	11 400	11 450	11 450	11 250	11 550	11 700	11 650	10 750	14
16			9 250	9 600	9 750	9 300	9 800	9 750	9 550	9 350	9 200	16
18				7 750	7 950	8 050	7 950	7 900	7 750	7 550	7 400	18
20					6 600	6 650	6 600	6 550	6 400	6 200	6 050	20
22					5 500	5 600	5 550	5 500	5 350	5 200	5 050	22
24						4 750	4 700	4 650	4 500	4 350	4 200	24
26							4 000	3 950	3 800	3 650	3 500	26
28							3 400	3 350	3 200	3 050	2 900	28
30								2 850	2 700	2 550	2 400	30
32								1 400	2 300	2 150	2 000	32
34										1 750	1 650	34
36										1 450	1 300	36
38											1 000	38
40											750	40

* Special Conditions Or Wire Rope Required
Capacities Depict Multiple Boom Modes

This information is not for crane operation. Operator must refer to the in-cab information for crane operation. Rated lifting capacities shown on fully extended outriggers do not exceed 75% of the tipping loads and on tires do not exceed 65% of the tipping loads.

8.8t Counterweight – On Tires – Stationary – Boom Centered Over Front Between Tire Tracks (All Capacities Are Listed In Kilograms)									
Radius (m)	Boom Length (m)								Radius (m)
	11.58	15.2	18.3	21.3	24.4	27.4	30.5	33.5	
4.5	25 100								4.5
5	23 150								5
6	19 900								6
7	17 050	18 450							7
8	13 250	14 800							8
9	10 550	12 000	12 700						9
10		9 950	10 650	10 950					10
12		7 050	7 750	8 100	8 250				12
14			5 800	6 150	6 350	6 400			14
16			4 450	4 800	5 000	5 100	5 050		16
18				3 750	3 950	4 050	4 050	4 000	18
20					3 150	3 250	3 200	3 200	20
22					2 500	2 600	2 600	2 550	22
24						2 100	2 050	2 050	24
26							1 650	1 600	26
28							1 250	1 250	28
30								950	30

This information is not for crane operation. Operator must refer to the in-cab information for crane operation. Rated lifting capacities shown on fully extended outriggers do not exceed 75% of the tipping loads and on tires do not exceed 65% of the tipping loads.

8.8t Counterweight – On Tires – Pick & Carry (Creep) – Boom Centered Over Front (All Capacities Are Listed In Kilograms)									
Radius (m)	Boom Length (m)								Radius (m)
	11.58	15.2	18.3	21.3	24.4	27.4	30.5	33.5	
4.5	24 000								4.5
5	21 900								5
6	18 450								6
7	15 800	16 850							7
8	13 250	14 700							8
9	10 550	12 000	12 700						9
10		9 950	10 650	10 950					10
12		7 050	7 750	8 100	8 250				12
14			5 800	6 150	6 350	6 400			14
16			4 450	4 800	5 000	5 100	5 050		16
18				3 750	3 950	4 050	4 050	4 000	18
20					3 150	3 250	3 200	3 200	20
22					2 500	2 600	2 600	2 550	22
24						2 100	2 050	2 050	24
26							1 650	1 600	26
28							1 250	1 250	28
30								950	30

8.8t Counterweight – On Tires – Stationary – 360° Rotation (All Capacities Are Listed In Kilograms)									
Radius (m)	Boom Length (m)								Radius (m)
	11.58	15.2	18.3	21.3	24.4	27.4	30.5	33.5	
5	12 700								5
6	9 100								6
7	6 700	8 050							7
8	4 950	6 250	6 950						8
9	3 650	4 950	5 600						9
10		3 950	4 600	4 900					10
12		2 450	3 100	3 400	3 600				12
14			2 050	2 350	2 550	2 600			14
16			1 300	1 600	1 750	1 850	1 850	1 800	16
18				1 000	1 150	1 250	1 250	1 200	18
20					700	800	800	750	20

This information is not for crane operation. Operator must refer to the in-cab information for crane operation. Rated lifting capacities shown on fully extended outriggers do not exceed 75% of the tipping loads and on tires do not exceed 65% of the tipping loads.

13.2t Counterweight – Fully Extended Outriggers – 360° Rotation
(All Capacities Are Listed In Kilograms)

Radius (m)	Boom Length (m)											Radius (m)	
	11.58	15.2–15.5	18.3–19.4	21.3	23.32–24.4	27.4	30.5	33.5	35.3–36.6	39.6	42.67		
2.5	80 000*												2.5
3	72 550	69 500	53 450	32 100									3
3.5	65 050	64 250	50 350	32 100									3.5
4	59 750	59 850	48 900	32 100	37 400								4
4.5	53 650	54 600	48 350	32 100	35 750	24 550							4.5
5	48 000	48 950	47 000	32 000	35 250	24 550							5
6	39 400	40 400	40 550	29 050	34 700	23 800	22 250	12 350					6
7	33 100	34 150	34 350	26 450	34 100	21 800	21 150	12 350					7
8	28 350	29 400	29 600	24 000	29 400	20 100	20 100	16 400	12 750	12 150			8
9	24 600	25 650	25 900	21 950	25 700	18 600	19 350	16 250	12 750	12 000	11 050		9
10		22 650	22 950	20 300	22 750	17 300	18 100	16 100	12 750	11 900	10 950		10
12		17 800	18 000	17 500	17 450	15 150	16 000	15 200	12 750	11 800	10 850		12
14			13 750	13 900	13 950	13 400	13 750	13 500	11 700	11 650	10 750		14
16			10 800	11 050	11 100	11 100	10 900	10 650	10 500	11 050	10 700		16
18				8 900	9 100	9 000	9 150	9 350	9 550	9 400	9 200		18
20					8 150	7 700	8 200	8 150	8 000	7 800	7 650		20
22					6 900	7 000	6 950	6 900	6 750	6 550	6 400		22
24						6 000	5 950	5 900	5 750	5 600	5 450		24
26							5 150	5 100	4 950	4 800	4 650		26
28							4 450	4 450	4 300	4 150	4 000		28
30								3 850	3 700	3 550	3 400		30
32								2 350	3 200	3 050	2 900		32
34									2 800	2 600	2 500		34
36										2 250	2 100		36
38											1 800		38
40											1 500		40

* Special Conditions Or Wire Rope Required
 Capacities Depict Multiple Boom Modes

This information is not for crane operation. Operator must refer to the in-cab information for crane operation. Rated lifting capacities shown on fully extended outriggers do not exceed 75% of the tipping loads and on tires do not exceed 65% of the tipping loads.

Fly Attachment Lift Capacity Charts – 75% – Optional

8.8t Counterweight – Fully Extended Outriggers – 360° Rotation (All Capacities Are Listed In Kilograms)									
42.67m Main Boom Length 2° Fly Offset					42.67m Main Boom Length 15° Fly Offset				
Radius (m)	Fly Length (m)				Radius (m)	Fly Length (m)			
	10.67	17.68	22.56	27.43		10.67	17.68	22.56	27.43
12	5 500				12				
14	5 500	3 850			14	5 200			
16	5 500	3 750	3 000		16	5 100			
18	5 500	3 700	3 000	2 350	18	5 000	3 300		
20	5 400	3 600	3 000	2 350	20	4 900	3 150	2 850	
22	5 300	3 500	3 000	2 350	22	4 750	3 050	2 650	2 100
24	4 500	3 400	2 950	2 200	24	4 650	2 950	2 450	1 950
26	3 750	3 300	2 700	2 050	26	4 050	2 850	2 300	1 800
28	3 150	3 200	2 550	1 850	28	3 400	2 750	2 150	1 650
30	2 650	2 900	2 350	1 750	30	2 900	2 700	2 050	1 550
32	2 250	2 450	2 200	1 600	32	2 400	2 600	1 900	1 400
34	1 850	2 050	2 000	1 500	34	2 050	2 350	1 800	1 300
36	1 550	1 750	1 700	1 400	36	1 700	2 000	1 700	1 250
38	1 250	1 450	1 400	1 300	38	1 400	1 700	1 600	1 150
40	1 000	1 200	1 100	1 100	40	1 100	1 400	1 300	1 050
42	750	950	900	900	42	850	1 150	1 050	1 000
44	550	750	700	650	44	650	900	850	850
46		550	500	500	46	450	700	650	650
48		400			48		500	450	450

This information is not for crane operation. Operator must refer to the in-cab information for crane operation. Rated lifting capacities shown on fully extended outriggers do not exceed 75% of the tipping loads and on tires do not exceed 65% of the tipping loads.

8.8t Counterweight – Fully Extended Outriggers – 360° Rotation (All Capacities Are Listed In Kilograms)									
42.67m Main Boom Length 30° Fly Offset					42.67m Main Boom Length 45° Fly Offset				
Radius (m)	Fly Length (m)				Radius (m)	Fly Length (m)			
	10.67	17.68	22.56	27.43		10.67	17.68	22.56	27.43
18	4 450				18				
20	4 350				20	3 950			
22	4 300				22	3 950			
24	4 200	2 550	2 050	1 650	24	3 900			
26	4 100	2 500	1 900	1 550	26	3 900	2 250	1 650	
28	3 650	2 400	1 800	1 400	28	3 850	2 200	1 550	1 250
30	3 100	2 350	1 700	1 300	30	3 250	2 150	1 500	1 200
32	2 600	2 300	1 600	1 250	32	2 750	2 150	1 450	1 100
34	2 200	2 250	1 550	1 150	34	2 300	2 100	1 400	1 050
36	1 800	2 200	1 450	1 050	36	1 900	2 100	1 350	950
38	1 500	1 900	1 400	1 000	38	1 550	2 050	1 300	900
40	1 200	1 600	1 350	950	40	1 250	1 750	1 250	850
42	950	1 300	1 300	900	42		1 450	1 200	800
44	700	1 050	1 050	850	44		1 150	1 150	750
46	500	850	800	800	46		900	900	750
48		600	600	600	48		650	700	700
50		400	400	450	50			450	500

This information is not for crane operation. Operator must refer to the in-cab information for crane operation. Rated lifting capacities shown on fully extended outriggers do not exceed 75% of the tipping loads and on tires do not exceed 65% of the tipping loads.

13.2t Counterweight – Fully Extended Outriggers – 360° Rotation (All Capacities Are Listed In Kilograms)									
42.67m Main Boom Length 2° Fly Offset					42.67m Main Boom Length 15° Fly Offset				
Radius (m)	Fly Length (m)				Radius (m)	Fly Length (m)			
	10.67	17.68	22.56	27.43		10.67	17.68	22.56	27.43
12	5 500				12				
14	5 500	3 850			14	5 200			
16	5 500	3 750	3 000		16	5 100			
18	5 500	3 700	3 000	2 350	18	5 000	3 300		
20	5 400	3 600	3 000	2 350	20	4 900	3 150	2 850	
22	5 300	3 500	3 000	2 350	22	4 750	3 050	2 650	2 100
24	5 150	3 400	2 950	2 200	24	4 650	2 950	2 450	1 950
26	4 950	3 300	2 700	2 050	26	4 550	2 850	2 300	1 800
28	4 250	3 200	2 550	1 850	28	4 350	2 750	2 150	1 650
30	3 650	3 100	2 350	1 750	30	3 850	2 700	2 050	1 550
32	3 150	2 950	2 200	1 600	32	3 350	2 600	1 900	1 400
34	2 700	2 800	2 100	1 500	34	2 900	2 550	1 800	1 300
36	2 350	2 550	1 950	1 400	36	2 500	2 400	1 700	1 250
38	2 000	2 200	1 850	1 300	38	2 150	2 300	1 650	1 150
40	1 700	1 900	1 750	1 200	40	1 800	2 100	1 550	1 050
42	1 450	1 650	1 550	1 100	42	1 550	1 800	1 500	1 000
44	1 200	1 400	1 300	1 050	44	1 300	1 550	1 400	950
46	1 000	1 150	1 100	1 000	46	1 050	1 300	1 250	900
48	800	950	900	900	48	850	1 100	1 050	850
50	650	800	700	700	50	650	900	850	800
52		600	550	550	52		700	650	650
54		450	400		54		550	500	500

This information is not for crane operation. Operator must refer to the in-cab information for crane operation. Rated lifting capacities shown on fully extended outriggers do not exceed 75% of the tipping loads and on tires do not exceed 65% of the tipping loads.

13.2t Counterweight – Fully Extended Outriggers – 360° Rotation (All Capacities Are Listed In Kilograms)									
42.67m Main Boom Length 30° Fly Offset					42.67m Main Boom Length 45° Fly Offset				
Radius (m)	Fly Length (m)				Radius (m)	Fly Length (m)			
	10.67	17.68	22.56	27.43		10.67	17.68	22.56	27.43
18	4 450				18				
20	4 350				20	3 950			
22	4 300				22	3 950			
24	4 200	2 550	2 050	1 650	24	3 900			
26	4 100	2 500	1 900	1 550	26	3 900	2 250	1 650	
28	4 050	2 400	1 800	1 400	28	3 850	2 200	1 550	1 250
30	3 900	2 350	1 700	1 300	30	3 750	2 150	1 500	1 200
32	3 550	2 300	1 600	1 250	32	3 600	2 150	1 450	1 100
34	3 050	2 250	1 550	1 150	34	3 150	2 100	1 400	1 050
36	2 650	2 200	1 450	1 050	36	2 700	2 100	1 350	950
38	2 250	2 150	1 400	1 000	38	2 300	2 050	1 300	900
40	1 900	2 050	1 350	950	40	1 950	1 950	1 250	850
42	1 600	1 950	1 300	900	42		1 900	1 200	800
44	1 350	1 700	1 250	850	44		1 800	1 150	750
46	1 100	1 450	1 200	800	46		1 500	1 150	750
48		1 200	1 200	750	48		1 250	1 150	700
50		1 000	950	700	50			1 050	650
52		750	750	650	52			800	650
54		600	600	600	54				600
56			400	450	56				450

This information is not for crane operation. Operator must refer to the in-cab information for crane operation. Rated lifting capacities shown on fully extended outriggers do not exceed 75% of the tipping loads and on tires do not exceed 65% of the tipping loads.

Main Boom Lift Capacity Charts – 85% – Metric

8.8t Counterweight – Fully Extended Outriggers – 360° Rotation (All Capacities Are Listed In Kilograms)												
Radius (m)	Boom Length (m)											Radius (m)
	11.58	15.2– 15.5	18.3– 19.4	21.3	23.32– 24.4	27.4	30.5	33.5	35.3– 36.6	39.6	42.67	
2.5	80 000*											2.5
3	70 500	69 550	53 450	32 100								3
3.5	64 300	64 300	50 350	32 100								3.5
4	57 100	58 050	48 900	32 100	37 400							4
4.5	50 500	51 500	48 350	32 100	35,750	24 550						4.5
5	45 150	46 150	46 300	32 000	35 250	24 550						5
6	37 000	38 000	38 200	29 050	34,700	23 800	22 250	12 350				6
7	31 050	32 100	32 300	26 450	32 050	21 850	21 150	12 350				7
8	26 500	27 600	27 850	24 000	27,600	20 100	20 100	12 350	16 450	12 150		8
9	22 950	24 050	24 300	21 950	24 100	18 600	19 350	12 350	16 250	12 000	11 050	9
10		21 200	21 650	20 300	21,300	17 350	18 100	12 350	16 100	11 900	10 950	10
12		16 000	16 150	16 350	16 400	15 150	16 000	12 350	15 200	11 800	10 850	11
14			12 250	12 400	12,450	12 450	12 250	11 550	12 000	11 650	10 700	12
16			9 750	9 850	10 050	9 850	10 050	10 350	10 450	10 250	10 100	13
18				8 550	8,750	8 450	8 750	8 700	8 550	8 350	8 200	14
20					7 300	7 350	7 300	7 250	7 100	6 900	6 750	15
22					6 150	6 250	6 150	6 100	5 950	5 800	5 700	16
24						5 350	5 300	5 250	5 100	4 900	4 800	17
26							4 550	4 500	4 350	4 200	4 050	18
28							3 900	3 850	3 750	3 550	3 400	19
30								3 350	3 200	3 050	2 900	20
32									2 750	2 600	2 450	21
34									2 350	2 200	2 050	22
36										1 850	1 700	23
38											1 400	24
40											1 150	25

* Special Conditions Or Wire Rope Required
Capacities Depict Multiple Boom Modes

This information is not for crane operation. Operator must refer to the in-cab information for crane operation. Rated lifting capacities shown on fully extended outriggers do not exceed 85% of the tipping loads and on tires do not exceed 75% of the tipping loads.

8.8t Counterweight – On Tires – Stationary – Boom Centered Over Front Between Tire Tracks (All Capacities Are Listed In Kilograms)									
Radius (m)	Boom Length (m)								Radius (m)
	11.58	15.2	18.3	21.3	24.4	27.4	30.5	33.5	
4.5	25 100								4.5
5	23 150								5
6	19 900								6
7	17 050	18 400							7
8	13 650	15 100							8
9	10 950	12 350	12 950						9
10		10 300	10 950	11 200					10
12		7 400	8 050	8 350	8 500				12
14			6 100	6 400	6 600	6 650			14
16			4 750	5 050	5 250	5 350	5 300		16
18				4 050	4 200	4 300	4 300	4 250	18
20					3 400	3 500	3 500	3 450	20
22						2 800	2 850	2 800	22
24							2 350	2 300	24
26								1 900	26
28								1 550	28
30								1 200	30

This information is not for crane operation. Operator must refer to the in-cab information for crane operation. Rated lifting capacities shown on fully extended outriggers do not exceed 85% of the tipping loads and on tires do not exceed 75% of the tipping loads.

8.8t Counterweight – On Tires – Pick & Carry (Creep) – Boom Centered Over Front (All Capacities Are Listed In Kilograms)									
Radius (m)	Boom Length (m)								Radius (m)
	11.58	15.2	18.3	21.3	24.4	27.4	30.5	33.5	
4.5	24 000								4.5
5	21 900								5
6	18 450								6
7	15 800	16 850							7
8	13 600	14 700							8
9	10 950	12 350	12 950						9
10		10 300	10 950	11 200					10
12		7 400	8 050	8 350	8 500				12
14			6 100	6 400	6 600	6 650			14
16			4 750	5 050	5 250	5 350	5 300		16
18				4 050	4 200	4 300	4 300	4 250	18
20					3 400	3 500	3 500	3 450	20
22					2 800	2 850	2 850	2 800	22
24						2 350	2 300	2 300	24
26							1 900	1 850	26
28							1 550	1 500	28
30								1 200	30

8.8t Counterweight – On Tires – Stationary – 360° Rotation (All Capacities Are Listed In Kilograms)									
Radius (m)	Boom Length (m)								Radius (m)
	11.58	15.2	18.3	21.3	24.4	27.4	30.5	33.5	
4.5	15 700								4.5
5	13 100								5
6	9 500								6
7	7 100	8 350							7
8	5 400	6 600	7 200						8
9	4 100	5 300	5 900						9
10		4 300	4 900	5 200					10
12		2 800	3 400	3 650	3 850				12
14			2 350	2 600	2 800	2 900			14
16			1 600	1 850	2 000	2 100	2 100	2 050	16
18				1 250	1 450	1 550	1 500	1 500	18
20					1 000	1 050	1 050	1 000	20
22					600	700	650	650	22

This information is not for crane operation. Operator must refer to the in-cab information for crane operation. Rated lifting capacities shown on fully extended outriggers do not exceed 85% of the tipping loads and on tires do not exceed 75% of the tipping loads.

13.2t Counterweight – Fully Extended Outriggers – 360° Rotation
(All Capacities Are Listed In Kilograms)

Radius (m)	Boom Length (m)											Radius (m)	
	11.58	15.2–15.5	18.3–19.4	21.3	23.32–24.4	27.4	30.5	33.5	35.3–36.6	39.6	42.67		
2.5	80 000*												2.5
3	71 300	69 550	53 450	32 100									3
3.5	65 050	64 300	50 350	32 100									3.5
4	59 750	59 900	48 900	32 100	37 400								4
4.5	53 650	54 550	48 350	32 100	35 750	24 550							4.5
5	48 000	48 950	47 000	32 000	35 250	24 550							5
6	39 350	40 400	40 550	29 050	34 700	23 800	22 250	12 350					6
7	33 100	34 150	34 350	26 450	34 100	21 850	21 150	12 350					7
8	28 350	29 350	29 600	24 000	29 400	20 100	20 100	12 350	16 450	12 150			8
9	24 600	25 650	25 900	21 950	25 700	18 600	19 350	12 350	16 250	12 000	11 050		9
10		22 650	22 900	20 300	22 750	17 350	18 100	12 350	16 100	11 900	10 950		10
12		18 100	18 550	17 500	18 200	15 150	16 000	12 350	15 200	11 800	10 850		12
14			14 950	15 100	15 100	13 400	14 300	11 550	13 550	11 650	10 700		14
16			11 850	12 050	12 100	12 000	11 900	10 350	11 650	11 050	10 700		16
18				9 850	9 900	9 900	9 700	9 350	9 550	10 050	10 100		18
20					8 300	8 250	8 350	8 500	8 700	8 600	8 450		20
22					7 650	7 000	7 650	7 600	7 450	7 300	7 150		22
24						6 500	6 600	6 550	6 400	6 250	6 100		24
26							5 800	5 750	5 600	5 400	5 300		26
28							5 050	5 000	4 850	4 700	4 550		28
30								4 400	4 250	4 100	3 950		30
32									3 750	3 550	3 400		32
34									3 250	3 100	2 950		34
36										2 700	2 550		36
38											2 250		38
40											1 900		40

* Special Conditions Or Wire Rope Required

Capacities Depict Multiple Boom Modes

This information is not for crane operation. Operator must refer to the in-cab information for crane operation. Rated lifting capacities shown on fully extended outriggers do not exceed 85% of the tipping loads and on tires do not exceed 75% of the tipping loads.

Fly Attachment Lift Capacity Charts – 85% – Optional

8.8t Counterweight – Fully Extended Outriggers – 360° Rotation (All Capacities Are Listed In Kilograms)									
42.67m Main Boom Length 2° Fly Offset					42.67m Main Boom Length 15° Fly Offset				
Radius (m)	Fly Length (m)				Radius (m)	Fly Length (m)			
	10.67	17.68	22.56	27.43		10.67	17.68	22.56	27.43
12	5 500				12				
14	5 500	3 850			14	5 200			
16	5 500	3 750	3 000		16	5 100			
18	5 500	3 700	3 000	2 350	18	5 000	3 300		
20	5 400	3 600	3 000	2 350	20	4 850	3 150	2 850	
22	5 300	3 500	3 000	2 350	22	4 750	3 050	2 650	2 100
24	5 100	3 400	2 950	2 200	24	4 650	2 950	2 450	1 950
26	4 300	3 300	2 700	2 050	26	4 550	2 850	2 300	1 800
28	3 700	3 200	2 550	1 850	28	3 950	2 750	2 150	1 650
30	3 150	3 050	2 350	1 750	30	3 350	2 700	2 050	1 550
32	2 700	2 900	2 200	1 600	32	2 900	2 600	1 900	1 400
34	2 300	2 500	2 100	1 500	34	2 450	2 500	1 800	1 300
36	1 950	2 150	1 950	1 400	36	2 100	2 400	1 700	1 250
38	1 650	1 850	1 800	1 300	38	1 800	2 050	1 650	1 150
40	1 350	1 550	1 500	1 200	40	1 500	1 750	1 550	1 050
42	1 150	1 300	1 250	1 100	42	1 250	1 500	1 450	1 000
44	900	1 100	1 050	1 050	44	1 000	1 250	1 250	950
46	700	900	850	850	46	800	1 050	1 000	900
48	550	700	650	650	48	600	850	800	800
50		550	500		50		650	600	600
52					52		500		

This information is not for crane operation. Operator must refer to the in-cab information for crane operation. Rated lifting capacities shown on fully extended outriggers do not exceed 85% of the tipping loads and on tires do not exceed 75% of the tipping loads.

8.8t Counterweight – Fully Extended Outriggers – 360° Rotation (All Capacities Are Listed In Kilograms)									
42.67m Main Boom Length 30° Fly Offset					42.67m Main Boom Length 45° Fly Offset				
Radius (m)	Fly Length (m)				Radius (m)	Fly Length (m)			
	10.67	17.68	22.56	27.43		10.67	17.68	22.56	27.43
18	4 450				18				
20	4 350				20	3 950			
22	4 300				22	3 950			
24	4 200	2 550	2 050	1 650	24	3 900			
26	4 100	2 500	1 900	1 550	26	3 850	2 250	1 650	
28	4 050	2 400	1 800	1 400	28	3 850	2 200	1 550	1 250
30	3 550	2 350	1 700	1 300	30	3 700	2 150	1 500	1 200
32	3 050	2 300	1 600	1 250	32	3 200	2 150	1 450	1 100
34	2 600	2 250	1 550	1 150	34	2 700	2 100	1 400	1 050
36	2 250	2 200	1 450	1 050	36	2 300	2 100	1 350	950
38	1 900	2 150	1 400	1 000	38	1 950	2 050	1 300	900
40	1 600	1 950	1 350	950	40	1 650	1 950	1 250	850
42	1 300	1 700	1 300	900	42		1 800	1 200	800
44	1 050	1 400	1 250	850	44		1 500	1 150	750
46	800	1 150	1 150	800	46		1 250	1 150	700
48		950	950	750	48		1 000	1 000	700
50		750	750	700	50			800	650
52		550	550	550	52			550	650

This information is not for crane operation. Operator must refer to the in-cab information for crane operation. Rated lifting capacities shown on fully extended outriggers do not exceed 85% of the tipping loads and on tires do not exceed 75% of the tipping loads.

13.2t Counterweight – Fully Extended Outriggers – 360° Rotation (All Capacities Are Listed In Kilograms)									
42.67m Main Boom Length 2° Fly Offset					42.67m Main Boom Length 15° Fly Offset				
Radius (m)	Fly Length (m)				Radius (m)	Fly Length (m)			
	10.67	17.68	22.56	27.43		10.67	17.68	22.56	27.43
12	5 500				12				
14	5 500	3 850			14	5 200			
16	5 500	3 750	3 000		16	5 100			
18	5 500	3 700	3 000	2 350	18	5 000	3 300		
20	5 400	3 600	3 000	2 350	20	4 850	3 150	2 850	
22	5 300	3 500	3 000	2 350	22	4 750	3 050	2 650	2 100
24	5 150	3 400	2 950	2 200	24	4 650	2 950	2 450	1 950
26	5 000	3 300	2 700	2 050	26	4 550	2 850	2 300	1 800
28	4 700	3 200	2 550	1 850	28	4 350	2 750	2 150	1 650
30	4 200	3 050	2 350	1 750	30	4 150	2 700	2 050	1 550
32	3 650	2 950	2 200	1 600	32	3 850	2 600	1 900	1 400
34	3 200	2 800	2 100	1 500	34	3 400	2 500	1 800	1 300
36	2 800	2 650	1 950	1 400	36	2 950	2 400	1 700	1 250
38	2 450	2 550	1 850	1 300	38	2 600	2 300	1 650	1 150
40	2 150	2 300	1 750	1 200	40	2 250	2 200	1 550	1 050
42	1 850	2 050	1 650	1 100	42	1 950	2 100	1 500	1 000
44	1 600	1 800	1 600	1 050	44	1 700	1 950	1 400	950
46	1 350	1 550	1 500	1 000	46	1 450	1 700	1 350	900
48	1 150	1 350	1 250	900	48	1 200	1 450	1 300	850
50		1 150	1 050	850	50		1 250	1 200	800
52		950	900	800	52		1 050	1 000	750
54		800	750	700	54		900	850	700
56		650	600	550	56			650	650
58					58			500	500

This information is not for crane operation. Operator must refer to the in-cab information for crane operation. Rated lifting capacities shown on fully extended outriggers do not exceed 85% of the tipping loads and on tires do not exceed 75% of the tipping loads.

13.2t Counterweight – Fully Extended Outriggers – 360° Rotation (All Capacities Are Listed In Kilograms)									
42.67m Main Boom Length 30° Fly Offset					42.67m Main Boom Length 45° Fly Offset				
Radius (m)	Fly Length (m)				Radius (m)	Fly Length (m)			
	10.67	17.68	22.56	27.43		10.67	17.68	22.56	27.43
18	4 450				18				
20	4 350				20	3 950			
22	4 300				22	3 950			
24	4 200	2 550	2 050	1 650	24	3 900			
26	4 100	2 500	1 900	1 550	26	3 850	2 250	1 650	
28	4 050	2 400	1 800	1 400	28	3 850	2 200	1 550	1 250
30	3 900	2 350	1 700	1 300	30	3 750	2 150	1 500	1 200
32	3 700	2 300	1 600	1 250	32	3 600	2 150	1 450	1 100
34	3 550	2 250	1 550	1 150	34	3 500	2 100	1 400	1 050
36	3 100	2 200	1 450	1 050	36	3 150	2 100	1 350	950
38	2 700	2 150	1 400	1 000	38	2 750	2 050	1 300	900
40	2 350	2 050	1 350	950	40	2 400	1 950	1 250	850
42	2 000	1 950	1 300	900	42	2 050	1 900	1 200	800
44	1 750	1 900	1 250	850	44		1 850	1 150	750
46	1 500	1 800	1 200	800	46		1 800	1 150	700
48		1 550	1 200	750	48		1 600	1 150	700
50		1 350	1 150	700	50			1 100	650
52		1 100	1 100	650	52			1 100	650
54		900	900	650	54				600
56			700	600	56				600
58			550	600	58				

This information is not for crane operation. Operator must refer to the in-cab information for crane operation. Rated lifting capacities shown on fully extended outriggers do not exceed 85% of the tipping loads and on tires do not exceed 75% of the tipping loads.

Link-Belt Cranes Lexington, Kentucky www.linkbelt.com

®Link-Belt is a registered trademark. Copyright 2017 We are constantly improving our products and therefore reserve the right to change designs and specifications.